

A Comprehensive Review of Runoff Estimation by the Curve Number Method

Ankit Balvanshi ¹, H.L. Tiwari ²

Department of Civil Engineering, Maulana Azad National Institute of Technology, Bhopal, India¹

Department of Civil Engineering, Maulana Azad National Institute of Technology, Bhopal, India²

ABSTRACT: Rainfall-runoff relationship is one of the most important phenomena in hydrologic design of hydrological structures and drainage systems. The estimation of runoff volume of a catchment is an important aspect in engineering planning, environmental impact assessment, flood forecasting and water balance calculations. There are basically two types of methods for the estimation of runoff namely the direct method and the indirect method. The direct method is based on the direct measurements while the other one is based on the equations. One of the indirect methods for the computation of runoff is the National Resource Conservation Service curve number method. This paper gives a review of the origin of the curve number method and development of the curve number equations. The Natural Resource Conservation Service curve number technique is a well-accepted tool for estimation of direct runoff from storm rainfall. CN model is used where constraints like slope, land cover, type of soil, area of watershed etc. are considered for runoff estimation.

KEYWORDS: Curve Number, Direct Runoff, Environmental Impact Assessment, Flood Forecasting, Slope and Land Cover.

I. INTRODUCTION

Runoff occurs when parts of the landscape is saturated or impervious. Basically there are two types of concepts which are responsible for runoff generation. These are the infiltration-excess runoff and the saturation excess runoff. In the infiltration-excess runoff concept, it is assumed that the overland flow occurs only when the rainfall intensity is greater than the infiltration rate at the soil surface. The second type of runoff generation also occurs where the soil surface is saturated and any further rainfall, even at low intensities, generates runoff that contributes to stream-flow. The more prevailing one is the saturation-excess runoff generation.

The direct runoff is the cause of numerous troubles and without proper technique to estimate it, no preventive measures can be applied. So for the prediction and assessment of runoff, a method called Curve Number Method was developed. In 1954, the Soil Conservation Service (SCS) which is now known as the Natural Resource Conservation Service (NRCS) developed the curve number method. This procedure was developed for application to hydrologic design activities connected with small agricultural watersheds. Ever since the development of the curve number method, it has turned out to be an extensively used method for estimating and predicting runoff. Because of its simplicity, predictability and stability, it is very popular and widely used all over the world.

II. ORIGIN AND HISTORICAL BACKGROUND

In 1933, the Soil Erosion Service (SES) was established in the United States. The SES demonstrated various soil conservation projects. Then the Soil Conservation Act of 1935 came out, which changed the name of the agency to Soil Conservation Service (SCS). SCS realized that there was a need to obtain hydrologic data and to obtain a simple procedure for estimating rates of runoff. With the passing of the Flood Control Act of 1936 (Public Law 74-738), the Department of Agriculture was authorized to carry out surveys and investigations of watersheds to install measures for retarding runoff and water flow and preventing soil erosion. The first effort was to obtain infiltration rates at many locations. The origin of the Curve Number methodology can be traced back to infiltrometer tests carried out by the SCS. The objective was to build-up basic data to evaluate the effects of watershed treatments and soil conservation measures on the rainfall-runoff process.

The SCS became the Natural Resources Conservation Service (NRCS) in 1994. After the passing of the rule Flood Prevention Act of 1954, various hydrologists started to develop runoff estimation techniques.

Mockus [11], Sherman [16 & 17] and Andrews [1] contributed to develop the unique procedures for estimating direct runoff from storm rainfall. Sherman [16 & 17] was one of the pioneers to suggest plotting direct runoff versus storm rainfall. Mockus [11] proposed that surface runoff of ungauged watersheds could be estimated by using information of soil, land use, antecedent rainfall, storm duration, and average annual temperature. The rainfall runoff relation of Mockus [11] and the soil, vegetation-land cover of Andrews became the building blocks of the SCS Curve Number method (Mishra and Singh [9]).

Andrews [1] developed a graphical procedure for estimating runoff from rainfall for combinations of soil texture and type, the amount of vegetative coverage, and conservation practices.

Plummer and Woodward [13] traced the origin and advancement of the method in the Soil Conservation Service of the U.S Department of Agriculture.

Mishra *et al.* [10] did the SCS-CN-based modelling of sediment yield. He concluded that this technique is simple, well acclaimed and give better results.

R. Kumar *et al.* [7] estimated the runoff using SCS CN method for an ungauged catchment using geomorphological instantaneous unit hydrograph (GIUH) models.

Ramakrishnan *et al.* [15] used the SCS-CN based approach for identifying the potential water harvesting sites in the Kali Watershed, Mahi River Basin.

V. Kumar *et al.* [8] did the analysis of the runoff for watershed using SCS-CN method and geographic information systems (GIS).

Somashekar *et al.* [18] estimated surface runoff of Hesaraghatta watershed. The analysis was carried using IRSID LISS III satellite images in the form of FCC using SCS curve number method and found that the runoff estimated by SCS method showed reasonable good result.

N. Nagarajan *et al.* [12] found that from the runoff values estimated by the curve number technique, it is possible to assess which month has more runoff, which month has a moderate runoff and which month has a low runoff. With the help of these values, irrigation scheduling, rotation of cropping pattern and selection of suitable crops can be suggested.

III. SCS URVE NUMBER METHOD

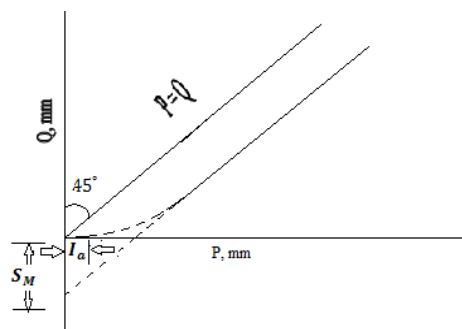

Figure from Das, G. [3]

According to the Soil Conservation Service National Engineering Handbook Section 4 (SCS [19] Chapter 10- Estimation of Direct Runoff from Storm Rainfall) the curve number is based on water balance equation and two assumptions. The water balance equation is:

$$P = Q + F + I_a \tag{I}$$

Where, P is rainfall depth; Q is direct runoff depth; F is actual retention after runoff begins & I_a is initial abstraction.

First hypothesis states that the ratio of the actual amount of direct runoff to the maximum potential runoff is equal to the ratio of the amount of actual retention to the amount of the maximum potential retention. Mathematically, the above can be written as follows:

$$\frac{F}{S} = \frac{Q}{P-I_a} \tag{II}$$

Now comparing eqs I & II we see two parameters S & I_a which are unknown. To remove the necessity for estimating both these parameters, the US Soil Conservation Service [19]) suggested a linear relation. It is written as follows:

$$I_a = \lambda S \tag{III}$$

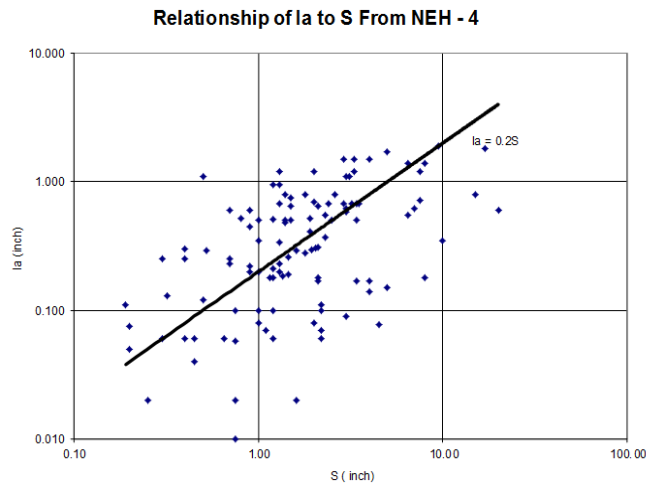

Where, λ is the initial abstraction ratio & S is soil storage index or maximum soil potential retention. The NRCS suggested a standard value of $\lambda = 0.2$. And, the NRCS curve number basic equation is as follows:

$$Q = \frac{(P-0.2S)^2}{P+0.8S} \quad \text{For } P \geq 0.2S \tag{IV}$$

$$Q = 0 \quad \text{For } P \leq 0.2S \tag{V}$$

For the ease, S is mapped into a dimensionless parameter Curve Number (CN). CN varies in the range of 0 to 100. If S is in inches, the equation is written as follows:

$$CN = \frac{1000}{10+S} \tag{VI}$$

If S is in millimeters, the equation becomes:

$$CN = \frac{25400}{254+S} \tag{VII}$$

The runoff derived by SCS-CN method is a function of runoff potential which can be expressed in terms of the runoff coefficient (ratio between the runoff and rainfall) which can be classified into three classes, viz., high (>40%), moderate (20–40%) and low (<20%). The watershed curve number serves as a substitute for soil storage index S.

IV. ANTECEDENT MOISTURE CONDITION

The antecedent moisture condition (AMC) of the soil is also referred to as antecedent precipitation, and the measure of the AMC existing on the day of the storm is then expressed as the Antecedent Precipitation Index (API). The moisture condition of a basin at the time of the storm greatly influences the peak outflow of runoff from the basin.

Suppose $(AMC)_t$ is the soil moisture condition on any day t , then $(AMC)_t = C_A(AMC)_{t-1}$, where C_A is a recession constant and $(AMC)_{t-1}$ is the AMC on the previous day. If there is no rainfall on the previous t day, then $t-1$ will be zero, and $(AMC)_t = C_A(AMC)_0$. If there is a rainfall on any of the days, then the volume of the rainfall on that day P_t is

to be added to the AMC of the next day, ie. $(AMC)_t = C_A(AMC)_{t-1} + P_t$. The value of C_A generally falls in the range of 0.85 to 0.98.

V. WATERSHED HYDROLOGIC SOIL GROUPS

There are four hydrologic soil groups ranging from A to D.

HSG Group A: Soils with high infiltration rates, consisting mainly deep sands and gravels with high rate of water transmission (final infiltration rate greater than 0.3 in/hr).

HSG B: Soils moderately fine to coarse soils having a moderate rate of water transmission (final infiltration rate of 0.15 in/hr to 0.30 in/hr).

HSG C: Moderately fine textured soils that may have a layer that impedes downward movement of water, with slow infiltration and water transmission rates (final infiltration rate of 0.05 to 0.15 in/hr).

HSG D: Clayey soils with permanent high water table or shallow soil over impervious material having very slow infiltration and water transmission rates (final infiltration rate less than 0.05 in/hr).

The land use and treatment classes are listed in NEH-4 Table 9.1. Few of the classes have three hydrologic conditions, poor, fair, or good based on the vegetative conditions. In the NRCS technique, CN changes with antecedent moisture condition. A single watershed can have more than one curve number.

The site AMC acts as a replacement for all other sources of inconsistencies, beyond that which could be attributed to soil, land use/treatment, and surface condition (Hjelmfelt [6]; Hawkins [4]. Hjelmfelt [5] proposed the concept of ordered data. So by this the data is orderly separated by magnitude, then frequency matched by realignment to form P:Q pairs corresponding to the same recurrence probability.

VI. RUNOFF CURVE NUMBERS, SCS(1986)

Description of Land Use	Hydrologic Soil Group			
	A	B	C	D
Paved parking lots, roofs, driveways	98	98	98	98
Streets and Roads:				
Paved with curbs and storm sewers	98	98	98	98
Gravel	76	85	89	91
Dirt	72	82	87	89
Cultivated (Agricultural Crop) Land*:				
Without conservation treatment (no terraces)	72	81	88	91
With conservation treatment (terraces, contours)	62	71	78	81
Pasture or Range Land:				
Poor (<50% ground cover or heavily grazed)	68	79	86	89
Good (50-75% ground cover; not heavily grazed)	39	61	74	80
Meadow (grass, no grazing, mowed for hay)	30	58	71	78
Brush (good, >75% ground cover)	30	48	65	73
Woods and Forests:				
Poor (small trees/brush destroyed by over-grazing or burning)	45	66	77	83
Fair (grazing but not burned; some brush)	36	60	73	79
Good (no grazing; brush covers ground)	30	55	70	77
Open Spaces (lawns, parks, golf courses, cemeteries, etc.):				
Fair (grass covers 50-75% of area)	49	69	79	84

Good (grass covers >75% of area)	39	61	74	80
Commercial and Business Districts (85% impervious)	89	92	94	95
Industrial Districts (72% impervious)	81	88	91	93
Residential Areas:				
1/8 Acre lots, about 65% impervious	77	85	90	92
1/4 Acre lots, about 38% impervious	61	75	83	87
1/2 Acre lots, about 25% impervious	54	70	80	85
1 Acre lots, about 20% impervious	51	68	79	84

Table from chow [2].

Using the above table the curve number values for different soil groups can be chosen and applied to curve number equation for runoff estimation.

VII. CONCLUSION

The CN method of estimating runoff volumes from rainfall is simple and easy to use. It is being used in a wide range of design situations by the practicing engineers and hydrologists. There appears to be no regional variation in CN for the same cover type. However, the lack of data may be influencing this conclusion. There appears to be seasonal variation in certain forested CN, which may reflect either seasonal moisture or leafing stages in hardwood (Price 1998). Use of remote sensing and GIS technology can be used to overcome the problem of conventional method for estimating runoff caused due to rainfall (Pradhan, R. et al [14]).

REFERENCES

- [1] Andrews, R.G., “The use of relative infiltration indices in computing runoff”. Rainfall-runoff relationship, V. P. Singh, ed., Water Resources Publications, Littleton, Colo, 1954.
- [2] Chow, V.T., “Handbook of Applied Hydrology”, McGraw-Hill, New York, 1986.
- [3] Das, G., “Hydrology and Soil Conservation Engineering”, PHI Learning Private Limited, New Delhi, pp.80-83, 2012.
- [4] Hawkins, R.H., “Discussion of Antecedent moisture condition probabilities”, Journal of Irrigation and Drainage Engineering 109: pp.298-299, (1983).
- [5] Hjelmfelt, A.T., “Empirical Investigation of Curve Number Technique”, Journal of the hydraulics division 106: pp.1471-1477, 1980.
- [6] Hjelmfelt, A.T., “Investigation of curve number procedure”, Journal of Hydrologic Engineering 17(6): pp.725-737, 1991.
- [7] Kumar, R. et al, “Runoff estimation for an ungauged catchment using geomorphological instantaneous unit hydrograph (GIUH) models”, Hydrol. Process, 21(14) : pp.1829–1840, 2007.
- [8] Kumar, V. et al, “Analysis of the Runoff for Watershed Using SCS-CN Method and Geographic Information Systems”, International Journal of Engineering Science and Technology, 2010.
- [9] Mishra, S.K., Singh, V.P., “Another Look At SCS-CN Method”, Journal of Hydrologic Engineering, 4: pp. 257-264, 1999.
- [10] Mishra, S. K. et al, “SCS-CN-based modeling of sediment yield”, J. Hydrol. 324: pp. 301–322, 2006.
- [11] Mockus, V., “Estimation of total (peak rates of) surface runoff for individual storms”, Exhibit A of Appendix B, Interim Survey Rep. Grand (Neosho) River Watershed, USDA, Washington, D.C., 1949.
- [12] Nagarajan, N. et al, “Impact of land use/land cover changes on surface runoff from a rural watershed, Tamilnadu, India”, Int. J. Water, Vol. 7, Nos. 1/2, pp.122–141, 2013.
- [13] Plummer, A., Woodward, D.E., “The origin and derivation of I_a/S in the runoff curve number system”, Proceeding of the International Water Resources Engineering Conference, Water Resources Engineering 98, ASCE Reston, VA, pp. 1260-1265, 1998.
- [14] Pradhan, R. et al, “Estimation of Rainfall Runoff using Remote Sensing and GIS in and around Singtam, East Sikkim”, International Journal of Geomatics and Geosciences, Vol. 1, pp.466, 2010.
- [15] Ramakrishnan, D. et al, “SCS-CN and GIS-based approach for identifying potential water harvesting sites in the Kali Watershed, Mahi River Basin, India”, J. Earth Syst. Sci. 118, No. 4, pp. 355–368, 2009.
- [16] Sherman, L. K., “Hydrograph of runoff”, Physics of the Earth, IX, hydrology, O. E. Meinzer, ed., McGraw-Hill, New York, 1942.
- [17] Sherman, L. K., “The unit hydrograph method”, Physics of the Earth, IX, hydrology, O. E. Meinzer, ed., McGraw-Hill, New York, 1949.
- [18] Somashekar et al, “Runoff estimation and morphometric analysis for Hesaraghatta watershed using IRS-ID LISS III FCC satellite data”, Journal of Indian Society of Remote Sensing, Vol. 39, pp. 95-106, 2011.
- [19] US Soil Conservation Service, National Engineering Handbook Section 4 - Hydrology, Washington DC, 1985.